



IBC3000

BULK BAG/BOX/DRUM FILLER



Taylor's IBC 3000 Fillers are engineered for a variety of materials and containers. The IBC's modular design allows complete flexibility from a free standing manual operation to a fully integrated and automated system handling bags, drums, and boxes.

COMPLETE BULK STORAGE AUTOMATION WITH SIMPLICITY AND FLEXIBILITY

- 100 lb to 3,000 lb capacity
- Granulars
- Powders
- Fill drums, bags, and seed boxes
- Compact modular design

Shown with optional Lift Platform, Pallet Dispenser and Conveyor System.



Single Source Pneumatic Conveying & Packaging Integration.



IBC3000 SPECIFICATIONS

Diagram dimensions are for reference only

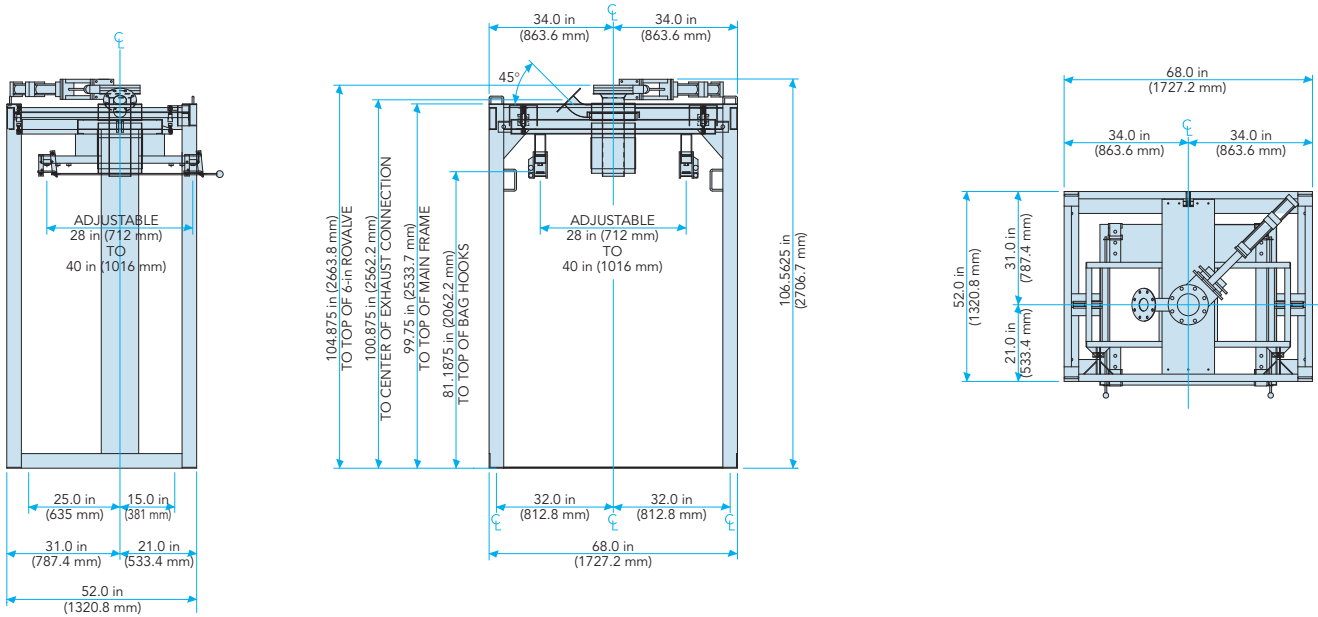

Dimensions	68 in x 52 in x 105 in (1,727 mm x 1,321 mm x 2,667 mm)
Speed	Up to 15 BPH or Up to 50 DPH
Accuracy	Up to 0.1%
Weight Range	100 lb to 3,000 lb (45 kg to 1,361 kg), up to 6,000 lb (2,722 kg) with special options
Construction	Tubular Carbon Steel blasted and painted
Electrical Requirements	115 Volt, single phase
Air Requirements	90 PSI (6.2 BAR)
Neck Seal	Inflatable neck seal and spout conform to all bag neck sizes
Clamp Design	Bag strap clamps are designed to accommodate various size bags
Dust Collection	Double-wall fill spout construction provides the displaced air venting to plant's central dust collection system
Popular Options	Stainless Steel Construction, Bag Liner Inflator, Automatic Bag Strap and Neck Seal Release, Drum Hood, Box Hood, Lift Platform, Step Sequence for convenience in bag hanging, Scale, Platform Vibration, Pallet Dispenser, Conveyor System, Electronic Controls, Round Product Inlet.



©2013 Magnum Systems, Inc. All rights reserved. Catalog number: MS.1010.0913



www.taylorproducts.com

Toll Free 888.882.9567 Phone 620.421.5550 Fax 620.421.5531

2205 Jothi Avenue, Parsons, Kansas 67357